



**Grupo Mexba**  
*Básculas, Redes y Sistemas*

Distribuidor Exclusivo:



# DPS-4600

Prepack Scale Printer



*Searching for*  
*a New Balance*

**VENTAS Y SERVICIO**  
Tel: 58222958 y 01 800 841 2991  
ventas.mexba@gmail.com  
www.mexba.com.mx

**Mexba**

# The DPS-4600 improves efficiency in all areas of the supermarket's operation.

## Large Color Touch Screen

The 10.4-inch, adjustable angle color TFT display ensures a good view for all working environments.

## Free-Layout function keys

Users can choose the color and position of the display function keys, according to their needs. This helps to simplify even the most complicated applications.

## Easy Label Exchange

The DPS-4600 has a very simple spooling structure for the label roll. This allows for quick, easy exchange of label rolls in the front-loading labeller.



## Space Efficiency

The DPS-4600 has a front-loading labeller, freeing up space on both sides of the machine for other uses, very important in a busy back room. Only 230mm width of space is needed to install the DPS-4600 single labeller version (330mm for twin labeller version).

Relia

Safe

Speedy

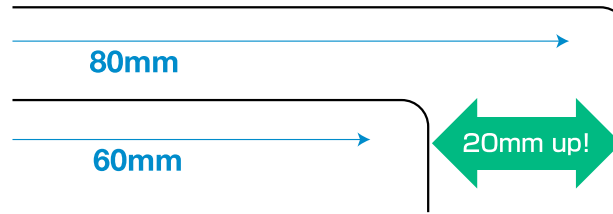

## Easy PLU Searching



The DPS-4600 supports the "Easy PLU searching" function. Searching for PLU (product) file among thousands of different files used to be the most troublesome part of back-room operations. The DPS-4600 helps operators search for PLUs in various ways.

# Accurate

Shoppers want detailed information about the products, such as "place of origin" and "traceability" on the labels. Shoppers also prefer "bargain price" clearly shown on the labels.

The second labeller is completely enclosed in a compact housing for the twin labeller version. The twin labeller can provide freely designed POP labels or supplemental labels to show ingredient or other product information.



## Various Labels, Easy-to-prepare

### Broad Print Width

Maximum print width is 80mm...20mm wider than the existing labels. The wider print width allows more information to be included on the labels to meet labelling regulations while still keeping advertising messages.

# DPS-4600

**DPS-4600**  
Single labeller type

**DPS-4600**  
Twin labeller type

Unit=mm/inches

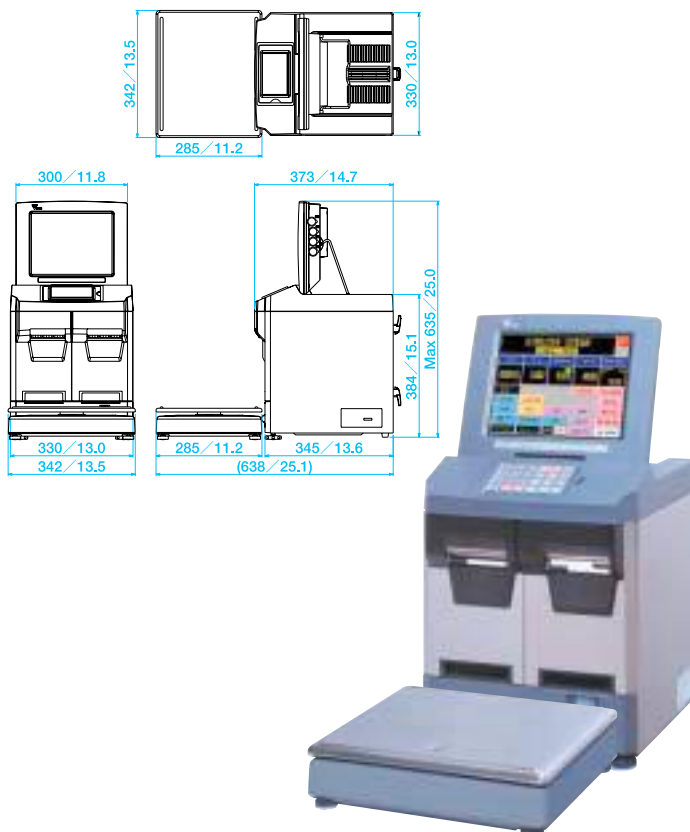
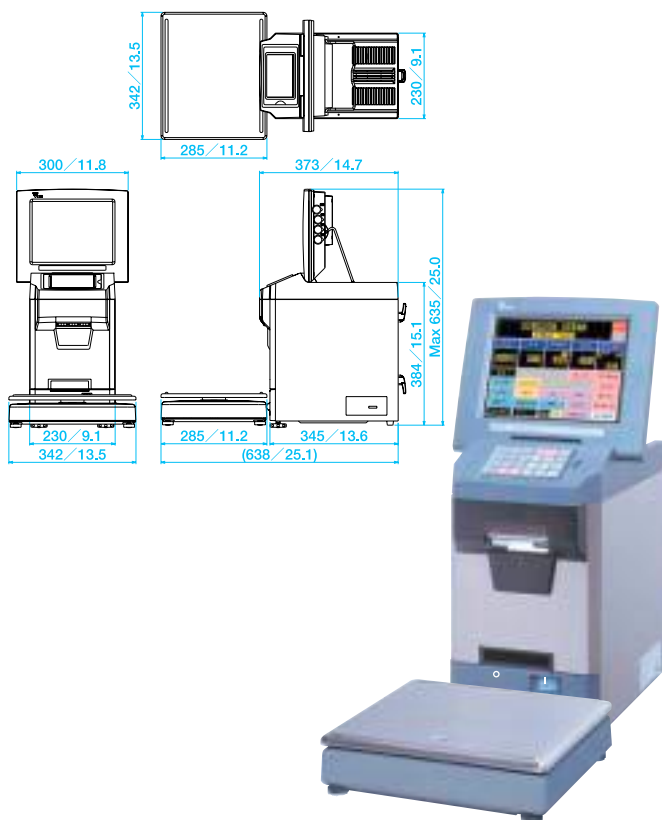

**DPS-4600 SPECIFICATIONS**

**Capacity**

Interval type	Multi-interval	Single interval
Capacity	Max 6/15kg	Max 3/6kg
Scale interval	e=2/5g	e=1/2g
		Max 30 lb
		e=0.01 lb

**Printer**

Type	Thermal printer
Dot density	8 dots/ mm
Printing speed	Max. 140mm/s
Printing width	25 to 80mm
Printing length	20 to 150mm
Back paper width	Max. 86mm
Label roll diameter	Max. 190mm
Label roll core diameter	42/ 76mm

**Console**

Display panel	TFT LCD color (10.4 inches)
Operational keys	Mechanical function keys and touch screen
Standard memory	4MB
Program installation	Flash memory

**Numerical display**

Tare	4 digits
Weight	6 digits
Unit price	6 digits
Total price	6 digits

**Programmable items**

PLU	Approx. 3000 items
Ingredients	2000 items
Advertising message	80 items
Extra print format	50 items
Text	25 items
Image	100 items
Barcode	UPC, EAN (8or13 digits) and etc.

Note : The memory area on 4600 software is not fixed for each file.  
The numbers above are an estimated maximum for each item.

**General**

Externals	Resin and stainless steel construction
Interface	IBM keyboard, RS-232C, Ethernet, 4-line
Power supply	AC 100/115/220-240V, 50/60Hz
Power consumption	1.2A, 140W
Net weight	
· Main unit	Single labeller type: 14.5kg/ 32.0 lb
· Scale platform	Twin labeller type: 21.0kg/ 46.3 lb
	3.8kg/ 8.4 lb



**Grupo Mexba**  
Básculas, Redes y Sistemas

**MEXBA REPRESENTANTE EXCLUSIVO:**



**DISTRIBUIDOR EXCLUSIVO**  
VENTAS Y SERVICIO

E-mail:ventas.mexba@gmail.com  
Tel: 58222958 y 01 800 841 2991  
www.mexba.com.mx